



pergole bioclimatiche QBox Shade

Alx • Smart • Blue





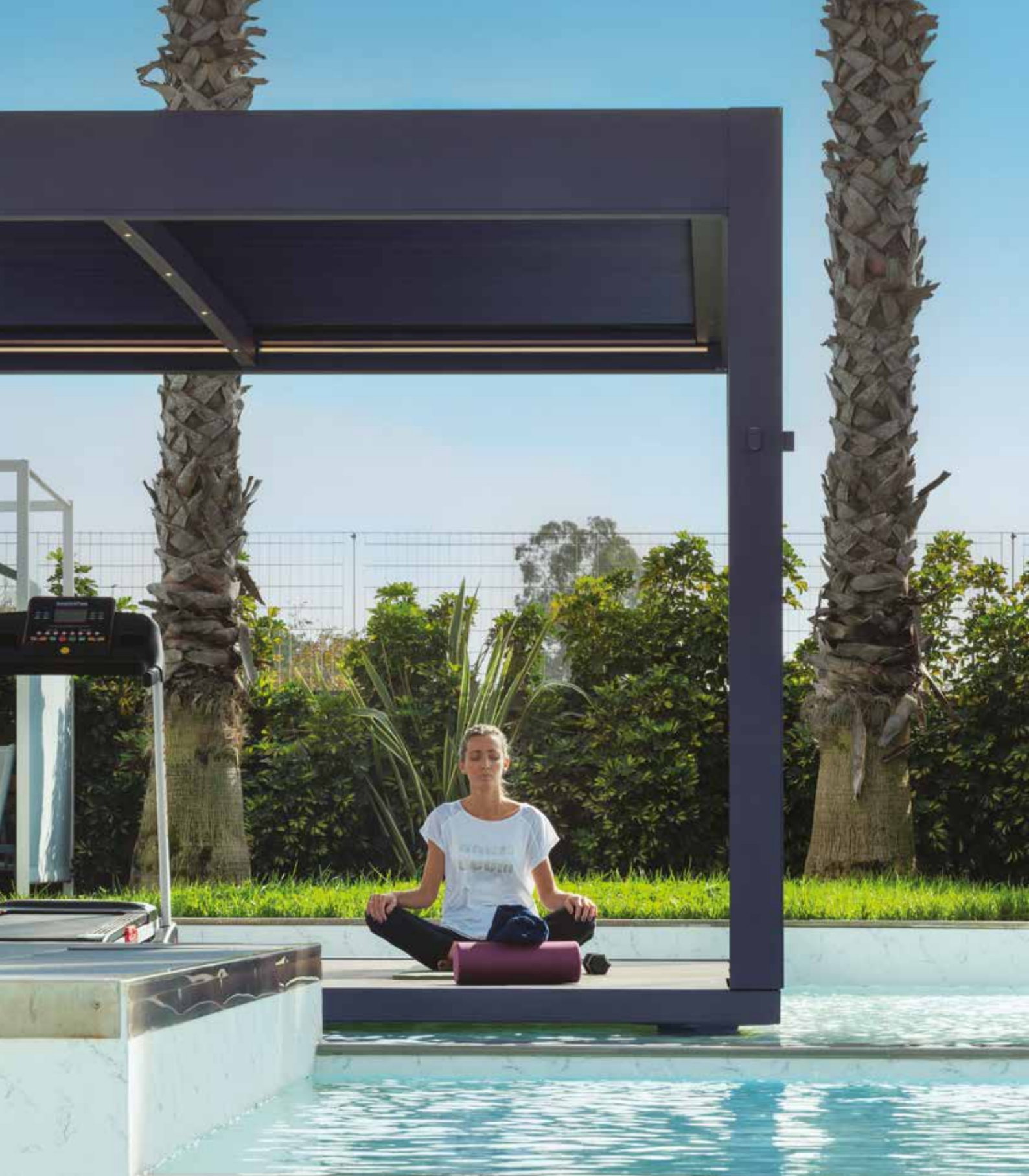

Create your dream outdoor space

IT

Le pergole bioclimatiche di **Sprech** mettono insieme la tradizione architettonica delle coperture outdoor con il più ampio concetto di wellness.

L'innovativa componente tecnologica è il punto di forza dei tre modelli di pergola bioclimatica QBox Shade: **Alx**, **Smart** e **Blue**, ognuno dei tre modelli è caratterizzato da una differente movimentazione delle lame.

La pergola bioclimatica **QBox Alx** è una pergola orientabile, la pergola bioclimatica **QBox Smart** ha un sistema di impacchettamento delle lame frangisole, la pergola bioclimatica **QBox Blue** ha un duplice sistema di movimentazione che permette di gestire **separatamente** l'orientamento e l'apertura o la chiusura delle lame.

Le pergole bioclimatiche di **Sprech** garantiscono il massimo grado di benessere in ogni momento della giornata.

EN

The new **Sprech** bioclimatic pergolas combine the architectural tradition of outdoor covers with the broader concept of wellness.

The innovative technological component is the strong point of the three bioclimatic pergola models QBox Shade: **Alx**, **Smart** e **Blue**, each of the three models is characterized by a different movement of the blades.

The **QBox Alx** bioclimatic pergola is an orientable pergola, the **QBox Smart** bioclimatic pergola has a system for packing the sunscreen blades, the **QBox Blue** bioclimatic pergola has a dual movement system that allows to **separately** manage orientation and opening or closing of the blades.

The **Sprech** bioclimatic pergolas guarantee the highest degree of wellness at any time of the day.

FR

Les nouvelles pergolas bioclimatiques **Sprech** réunissent la tradition architecturale des couvertures extérieures et le concept le plus vaste de bien-être.

La composante technologique innovante est le point fort des trois modèles de pergola bioclimatique QBox Shade: **Alx**, **Smart** et **Blue**, chacun des trois modèles se caractérise par un mouvement différent des lames.

La pergola bioclimatique **QBox Alx** est une pergola orientable, la pergola bioclimatique **QBox Smart** dispose d'un système d'ouverture des lames, la pergola bioclimatique **QBox Blue** dispose d'un système de double mouvement qui permet de gérer **séparément** l'orientation et l'ouverture ou la fermeture des lames.

Les pergolas bioclimatiques de **Sprech** garantissent le maximum de bien-être à tout moment de la journée.



IT

L'illuminazione LED integrata crea la giusta atmosfera, dal tramonto fino a sera. Con i nuovi optional, si possono allestire aree living dotate di ogni comodità.

L'allestimento delle pergole può essere completato con WI-FI per lo smart working, impianto audio per le serate con gli amici, bluetooth per condividere i momenti più belli, illuminazione integrata di diverso tipo come LED, RGB, faretti segnapasso, per godersi l'aria aperta anche dopo il tramonto.

EN

The integrated LED lighting creates the right atmosphere, from sunset to late night. With the new options of the bioclimatic pergolas can be set up a living area equipped with every comfort. The staging can be completed with: wifi for smartworking, audio system for evenings with friends, bluetooth for sharing beautiful moments, integrated lighting, like LED, RGB, step lights on the columns, to live in open air, also after sunset.



FR

L'éclairage à LED intégré crée l'atmosphère qu'il faut, du coucher du soleil jusque tard dans la nuit. Avec les nouvelles options de les pergolas bioclimatique, un espace de vie équipé de tout les comforts peut être agréablement aménager. L'équipement de les pergolas Bioclimatiques peut être couronné par: le wifi pour le Smart Working, le système audio pour les fêtes entre amis, le bluetooth pour partager les meilleurs moments, l'éclairage intégré, comme LED, RGB, spots sur les lampes Led sur poteaux pour passer une belle soirée dehors même après le coucher du soleil.

IT

La robustezza della struttura è garanzia di stabilità, resistenza nel tempo e sicurezza, qualità di una produzione interamente Made in Italy.

EN

The sturdiness of the structure is a guarantee of stability, durability, and safety, characteristic of a production entirely Made in Italy.

FR

La robustesse de la structure est une garantie de stabilité, de résistance dans la durée et de sécurité : qualité d'une production entièrement Made in Italy.



IT

Le pergole bioclimatiche Qbox Shade (**Alx, Smart e Blue**) sono disponibili in 42 colori e in **3 varianti limited Sprech Special Colors**, con certificazione Qualicoat Class 2, a garanzia di un'eccezionale superdurabilità con massimi livelli di ritenzione della brillantezza, stabilità del colore e resistenza ai raggi UV.

EN

The bioclimatic pergola Qbox Shade (**Alx, Smart and Blue**) are available in 42 colours and in **three color variations limited edition Sprech Special Colors**, with Qualicoat Class 2 certification, a guarantee of exceptional durability with maximum levels of gloss retention, colour stability, and resistance to UV rays.

FR

Les pergolas bioclimatique Qbox Shade (**Alx, Smart et Blue**) sont disponibles en 42 couleurs et **trois variations de couleurs, édition limitée Sprech Special Couleurs**, avec la certification Qualicoat Class 2, en garantie d'une super-durabilité exceptionnelle avec des niveaux maximaux de retenue de la brillance, de stabilité de la couleur et de résistance aux rayons UV.

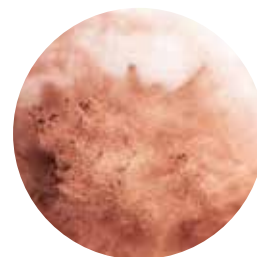

Limited Sprech Special Colors



CARTA DA ZUCCHERO
SUGAR PAPER
PAPIER DE SUCRE



NOTTE STELLATA
STARRY NIGHT
NUIT ÉTOILÉE



TERRA ROSSA
RED EARTH
TERRE ROUGE





pergola bioclimatica QBox **Alx**



IT

La pergola **QBox Alx** nasce per rispondere all'esigenza di vivere gli spazi esterni in ogni momento dell'anno, senza rinunciare a un design essenziale e innovativo, capace di adattarsi a qualunque tipo di contesto paesaggistico.

Si tratta di una pergola bioclimatica con struttura in alluminio e giunti angolari e piastre di base in **acciaio INOX**. Disponibile anche con struttura portante in acciaio.

La pergola è verniciata con polveri epossidiche ed è caratterizzata da un innovativo sistema di movimentazione delle lame con fulcro basso che consente l'aderenza ermetica delle lame alla guarnizione perimetrale.

L'eccezionale aderenza delle lame chiuse alla guarnizione perimetrale garantisce, in caso di pioggia, il completo deflusso dell'acqua piovana, totalmente invisibile agli occhi di chi è al riparo sotto la struttura.

Le lame frangisole, oltre a riparare da vento e pioggia, bloccano i raggi solari e proteggono dai raggi UV.

Grazie alla possibilità di regolare l'apertura delle lame l'ambiente sotto la copertura rimane sempre piacevolmente ventilato e allo stesso tempo si ha il pieno controllo della sua luminosità.

EN

The **QBox Alx** pergola was created to meet the need to experience outdoor spaces at any time of the year, without sacrificing a minimalist and innovative design, capable of adapting to any type of landscape. It is a bioclimatic pergola with an aluminium structure, and corner joints and base plates in **stainless steel**. Steel pergola is also available.

The pergola is coated with epoxy powders and is characterized by an innovative system for moving the slats with a low fulcrum that makes the slats adhere hermetically to the perimeter seal.

The exceptional adherence of the closed slats to the perimeter seal guarantees, in case of rain, the complete outflow of rainwater, completely invisible to the eyes of those who are sheltered under the structure.

The sunshade slats, in addition to sheltering from wind and rain, block the sunrays and protect against UV rays. Because you can adjust the opening of the slats, the environment under the cover always remains pleasantly ventilated and at the same time you have full control of its brightness.

FR

La pergola QBox Alx a été créée pour répondre au besoin de vivre les espaces extérieurs à tout moment de l'année, sans renoncer à un design essentiel et innovant, capable de s'adapter à tout type de contexte paysager. C'est une pergola bioclimatique avec une structure en aluminium, des joints d'angle et des bases en **acier INOXYDABLE**. La pergola est également disponible en acier.

La pergola est peinte en poudres époxy et se caractérise par un système innovant de lames à point d'appui bas qui permet une adhérence hermétique des lames au joint périmétrique.

L'adhérence exceptionnelle des lames fermées au joint périmétrique garantit, en cas de pluie, l'écoulement complet de l'eau de pluie, totalement invisible aux yeux de ceux qui sont abrités sous la structure. Les lames du pare-soleil, en plus de protéger du vent et de la pluie, bloquent les rayons du soleil et protègent des rayons UV. Grâce au réglage de l'ouverture des lames, l'environnement sous la couverture reste toujours agréablement ventilé et vous pouvez à tout moment contrôler l'intensité de la lumière.



I plus QBox Alx

1 **Struttura in alluminio con giunti angolari e piastre di base in acciaio INOX** (componenti validi per le strutture in alluminio)

- > **Aluminium structure with stainless corner joints and base plates** (valid components for aluminium structure)
- > **Structure en aluminium avec joints angulaires et plaques de base en acier inoxydable** (composants valables pour les structures en aluminium)

4 **Il frangitratta centrale aiuta l'acqua a confluire nelle travi perimetrali della struttura e ne garantisce solidità, stabilità e tenuta ai carichi accidentali.**

- > The intermediate bar allows water to flow into the perimeter beams of the structure and ensures stability and resistance to significant accidental loads
- > La barre intermédiaire permet l'évacuation de l'eau dans les poutres périphériques de la structure et assure solidité, stabilité et tenue aux charges accidentelles.

2 **Possibilità di regolare l'orientamento delle lame garantendo un ambiente piacevolmente ventilato**

- > Possibility to adjust the louvres orientation ensuring a pleasantly ventilated environment
- > Possibilité de régler l'inclinaison des lames assurant un environnement agréablement ventilé

3 **Riparo dai raggi UV, dalla pioggia e dal vento**

- > Protection from UV rays, rain, and wind
- > Protège des rayons UV, de la pluie et du vent

5 **Secondo le condizioni previste dalla norma UNI EN 12056, la gronda garantisce la massima capienza di acqua piovana e lo scarico integrato nei montanti ne permette il normale deflusso.**

- > Selon les conditions prévues par la norme UNI EN 12056, la gouttière garantit la capacité maximale d'eau de pluie et le drain intégré dans les montants permet son écoulement normal.
- > According to the conditions foreseen by the UNI EN 12056 standard, the gutter guarantees the maximum capacity of rainwater and the integrated drain in the uprights allows the normal outflow.

QBox Alx

Garanzia e qualità del Made in Italy

Made in Italy guarantee and quality · Garantie et qualité du Made in Italy





pergola bioclimatica QBox **Smart**



IT

La famiglia delle bioclimatiche di **Sprech** si allarga con la nuova pergola **QBox Smart**, una pergola bioclimatica in alluminio con giunti angolari e piastre di base in **acciaio INOX**. Disponibile anche con struttura portante in acciaio.

La nuova pergola bioclimatica **QBox Smart** è la soluzione outdoor ideale per chi ricerca un prodotto originale, innovativo e di design.

Il tetto è regolato da un meccanismo a **pantografo** che permette di impacchettare facilmente le lame e godere del cielo a vista.

Il tetto chiuso garantisce la protezione totale dai raggi UV, dalla pioggia e dalle intemperie.

La pergola bioclimatica **QBox Smart** è disponibile in oltre 40 colori e nei colori special edition di **Sprech**.

Un sistema Smart per una pergola Smart.

EN

The bioclimatic family of **Sprech** extends with the new **QBox Smart** pergola, a bioclimatic pergola in aluminium with corner joints and base plates in **stainless steel**.

Steel pergola is also available.

The new **QBox Smart** bioclimatic pergola is the ideal outdoor solution for those looking for an original, innovative, and aesthetic product.

The roof is controlled by a **pantograph** mechanism that allows you to easily open the covering and enjoy the view of the sky.

The closed roof guarantees total protection from UV rays and bad weather, including rain. The **QBox Smart** bioclimatic pergola is available in over 40 colours and in the special edition colours of **Sprech**. A Smart system for a Smart pergola.

FR

La famille bioclimatique de **Sprech** s'agrandit avec la nouvelle pergola **QBox Smart**, une pergola bioclimatique en aluminium avec joints d'angle et bases en **acier INOX**.

La pergola est également disponible en acier.

La nouvelle pergola bioclimatique **QBox Smart** est la solution extérieure idéale pour tous ceux qui recherchent un produit original, innovant et design.

Le toit est régulé par un mécanisme à **pantographes** qui vous permet d'ouvrir facilement la couverture et de profiter du ciel visible.

Le toit fermé garantit une protection totale contre les rayons UV, la pluie et les intempéries.

La pergola bioclimatique **QBox Smart** est disponible dans plus de 40 couleurs et dans les couleurs de l'édition spéciale de **Sprech**. Un système Smart pour une pergola Smart.



I plus QBox Smart

1 **Struttura in alluminio con giunti angolari e piastre di base in acciaio INOX** (componenti validi per le strutture in alluminio)

- > **Aluminium structure with stainless corner joints and base plates** (valid components for aluminium structure)
- > **Structure en aluminium avec joints angulaires et plaques de base en acier inoxydable** (composants valables pour les structures en aluminium)

4 **Riparo dai raggi UV, dalla pioggia e dal vento**

- > Protection from UV rays, rain, and wind
- > Protège des rayons UV, de la pluie et du vent

2 **Tetto regolato da un sistema di pantografi.**

- > Coverage regulated by pantographs system.
- > Couverture régulée par un système de pantographes

5 **Il frangitratta centrale aiuta l'acqua a confluire nelle travi perimetrali della struttura e ne garantisce solidità, stabilità e tenuta ai carichi accidentali.**

- > The intermediate bar allows water to flow into the perimeter beams of the structure and ensures stability and resistance to significant accidental loads
- > La barre intermédiaire permet l'évacuation de l'eau dans les poutres périphériques de la structure et assure solidité, stabilité et tenue aux charges accidentelles.

3 **Lame orientabili e retrattili con unica movimentazione**

- > Orientable and retractable louvres with single movement
- > Lames réglables et rétractables avec un seul mouvement

6 **Secondo le condizioni previste dalla norma UNI EN 12056, la gronda garantisce la massima capienza di acqua piovana e lo scarico integrato nei montanti ne permette il normale deflusso.**

- > Selon les conditions prévues par la norme UNI EN 12056, la gouttière garantit la capacité maximale d'eau de pluie et le drain intégré dans les montants permet son écoulement normal.
- > According to the conditions foreseen by the UNI EN 12056 standard, the gutter guarantees the maximum capacity of rainwater and the integrated drain in the uprights allows the normal outflow.

QBox Smart

Garanzia e qualità del Made in Italy

Made in Italy guarantee and quality - Garantie et qualité du Made in Italy







pergola bioclimatica
QBox **Blue**



IT

Con il nuovo **QBox Blue** di **Sprech**, nessuna condizione meteo potrà cogliervi impreparati. Grazie alla pergola bioclimatica **QBox Blue**, avrete un microclima perfetto, al riparo da vento e pioggia, gradevole con la prima luce tenue del giorno e utile a schermare la luce del sole nelle ore più calde, senza rinunciare a una ventilazione naturale.

La possibilità di personalizzare **l'inclinazione, l'apertura, o l'impacchettamento delle lame** rende lo spazio outdoor sottostante un'oasi di benessere.

EN

No weather conditions can catch you unprepared: thanks to the **Qbox Blue** bioclimatic pergola you will have a perfect microclimate, sheltered from wind and rain, pleasant with the first soft light of the day, and useful for shielding the sunlight in the hottest hours, without sacrificing natural ventilation.

The possibility to customize the **inclination, opening or closing of the louvres** allows you to make the outdoor space below an oasis of wellness.

FR

Aucune condition météo ne pourra vous prendre au dépourvu : grâce à la pergola bioclimatique **Qbox Blue**, vous aurez un microclimat parfait, à l'abri du vent et de la pluie, agréable avec les premières lueurs du jour et utile pour masquer la lumière du soleil durant les heures les plus chaudes, sans renoncer à une ventilation naturelle.

La possibilité de personnaliser **l'inclinaison, l'ouverture ou l'embalage des lames** vous permet de faire de l'espace extérieur en dessous une oasis de bien-être.







IT

Il vantaggio della pergola bioclimatica **QBox Blue**, struttura in alluminio con giunti angolari e piastre di base in **acciaio INOX**, grazie alla sua copertura orientabile e retrattile, sta nella possibilità di regolare luminosità, aerazione e scenario a seconda delle esigenze, scegliendo tra molteplici differenti combinazioni. Disponibile anche con struttura portante in acciaio.

Un duplice sistema di movimentazione permette di gestire separatamente l'orientamento e l'apertura o la chiusura delle lame.

Il design della pergola bioclimatica **QBox Blue** è pensato per ogni contesto paesagistico, limitando al massimo l'impatt visivo.

EN

The advantage of the **Qbox Blue** bioclimatic pergola, aluminum structure and **stainless steel** corner joints and base plates, thanks to its adjustable and retractable cover, lies in the possibility of adjusting brightness, ventilation, and appearance according to your needs, choosing from many different combinations. Steel pergola is also available.

A dual movement system allows you to manage the orientation and opening or closing of the slats separately.

The design of the **Qbox Blue** bioclimatic pergola is designed for any landscape, reducing the visual impact as much as possible.

FR

Grâce à sa couverture orientable et rétractable, l'avantage de la pergola bioclimatique **Qbox Blue**, structure en aluminium et joints angulaires et plaques de base en **acier inoxydable**, réside dans la possibilité de réguler la luminosité, l'aération et le scénario en fonction des exigences, en choisissant parmi les différentes combinaisons. La pergola est également disponible en acier.

Un double système de mouvement permet de gérer séparément l'orientation et l'ouverture ou la fermeture des lames.

Le design de la pergola bioclimatique **Qbox Blue** est pensé pour tous les environnements paysagers, en limitant au maximum son impact visuel.



I plus QBox Blue

- 1** Innovativo sistema di duplice movimentazione delle lame: orientamento e impacchettamento
 - > Innovative system of dual movement of the slats: orientation and opening
 - > Système innovant de double mouvement des lames: orientation et ouverture
- 2** Doppia automazione che garantisce vari gradi di ventilazione
 - > Double automation that guarantees various degrees of ventilation
 - > Double automation qui garantit différents degrés de ventilation orientation et ouverture
- 3** **Struttura in alluminio con giunti angolari e piastre di base in acciaio INOX (componenti validi per le strutture in alluminio)**
 - > **Aluminium structure with stainless corner joints and base plates (valid components for aluminium structure)**
 - > **Structure en aluminium avec joints angulaires et plaques de base en acier inoxydable (composants valables pour les structures en aluminium)**
- 4** Riparo dai raggi UV, dalla pioggia e dal vento.
 - > Protection from UV rays, rain, and wind
 - > Protège des rayons UV, de la pluie et du vent
- 5** Il frangitratta centrale aiuta l'acqua a confluire nelle travi perimetrali della struttura e ne garantisce solidità, stabilità e tenuta ai carichi accidentali.
 - > The intermediate bar allows water to flow into the perimeter beams of the structure and ensures stability and resistance to significant accidental loads
 - > La barre intermédiaire permet l'évacuation de l'eau dans les poutres périphériques de la structure et assure solidité, stabilité et tenue aux charges accidentelles.
- 6** **Secondo le condizioni previste dalla norma UNI EN 12056, la gronda garantisce la massima capienza di acqua piovana e lo scarico integrato nei montanti ne permette il normale deflusso.**
 - > **Selon les conditions prévues par la norme UNI EN 12056, la gouttière garantit la capacité maximale d'eau de pluie et le drain intégré dans les montants permet son écoulement normal.**
 - > **According to the conditions foreseen by the UNI EN 12056 standard, the gutter guarantees the maximum capacity of rainwater and the integrated drain in the uprights allows the normal outflow.**

QBox blue

Garanzia e qualità del Made in Italy

Made in Italy guarantee and quality · Garantie et qualité du Made in Italy





QBox Blue
diversi scenari
in una sola pergola

Alx

Lame orientabili
Tilting louvres
Lames réglables

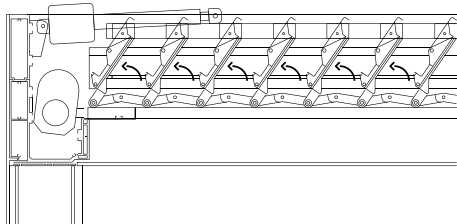

La possibilità di orientare l'inclinazione delle lame permette di regolare la luminosità e la ventilazione dell'ambiente, mantenendo una piacevole brezza in qualunque ora della giornata.

The possibility of orienting sunshade slats inclination allows to adjust environment brightness and ventilation, keeping a pleasant breeze at any time of the day.

La possibilité de gérer l'orientation des lames brise-soleil permet de régler la luminosité et la ventilation de l'espace tout en maintenant une agréable brise à toute heure de la journée.

Smart

Lame retrattili
Retractable louvres
Lames rétractables

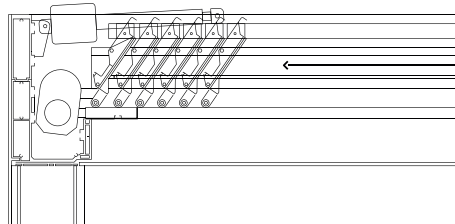

Le lame retrattili, guidate da un sistema a pantografo, permettono di cambiare e godere di un nuovo scenario a seconda delle esigenze.

The retractable louvres, through a pantograph system, allow you to change and enjoy a new scenario according to your needs.

Les lames rétractables, grâce à un système de pantographe, vous permettent de changer et de profiter d'un nouveau scénario en fonction de vos besoins.

Blue

Lame orientabili e retrattili
Tilting and retractable louvres
Lames réglables et rétractables

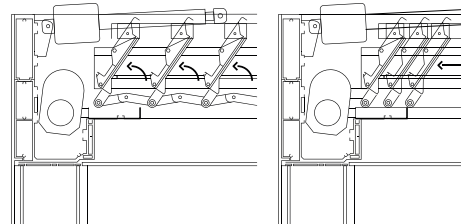

Le lame orientabili e retrattili permettono di personalizzare, a seconda delle necessità e delle condizioni atmosferiche, il microclima all'interno dello spazio outdoor creando un'area di comfort e benessere per tutta la famiglia. Un duplice sistema di movimentazione permette di gestire separatamente l'orientamento e l'apertura o chiusura delle lame.

The orientable and retractable louvres allow you to customize according to needs and weather conditions the perfect microclimat in your outdoor space creating a comfort and well-being area for the whole family. A dual movement system allow you to manage the orientation and opening or closing of the slats separately.

Les lames brise-soleil orientables et rétractable permettent de personnaliser selon les besoins et le conditions atmosphériques, le microclimat à l'intérieur de l'espace outdoor en créant une zone. Un double système de mouvement permet de gérer séparément l'orientation et l'ouverture ou la fermeture des lames.

Vantaggi delle pergole bioclimatiche / Advantages of bioclimatic pergolas / Avantages des pergolas bioclimatique

Ripara dalla pioggia
Shelter from the rain
A l'abri de la pluie

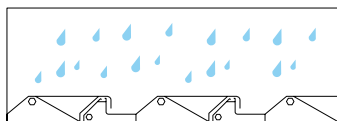

Ripara dai raggi solari
Shelters from the sun's rays
Abris des rayons du soleil

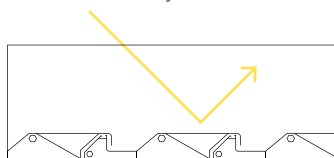

Garantisce un ambiente ventilato
Guaranteed a ventilated environment
Garantit un environnement ventilé

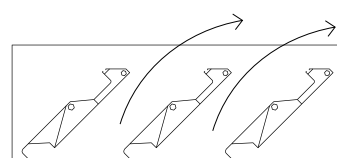

BARRA FRANGITRATTA: GARANTISCE IL DEFLUSSO DELLE ACQUE E CONFERISCE STABILITÀ ALLA STRUTTURA

Intermediate bar: ensure the outflow of water and confers structure stability / Barre intermédiaire: assure l'évacuation de l'eau et confère la stabilité à la structure

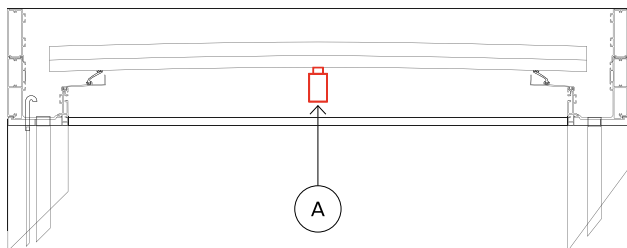

A

IT La barra frangitratta apporta una leggera curvatura alle lame che consente il normale deflusso delle acque pluviali nelle gronde perimetrali e al contempo, garantisce l'aumento del carico accidentale sulla struttura.

EN The intermediate bar allows the bending of the louvers to ensure the outflow of water and the increase of the accidental load on the structure.

FR La barre intermédiaire permet le cintrage des lamelles pour assurer l'évacuation de l'eau et l'augmentation de la charge accidentelle sur la structure.

ACCESSORI DI SERIE / STANDARD ACCESSORIES / ACCESSOIRES STANDARD

Sistema di scarico dell'acqua con pluviale integrato / Water drainage system with integrated drain pipe (standard) / Système d'évacuation d'eau avec tuyau d'évacuation intégré (standard)

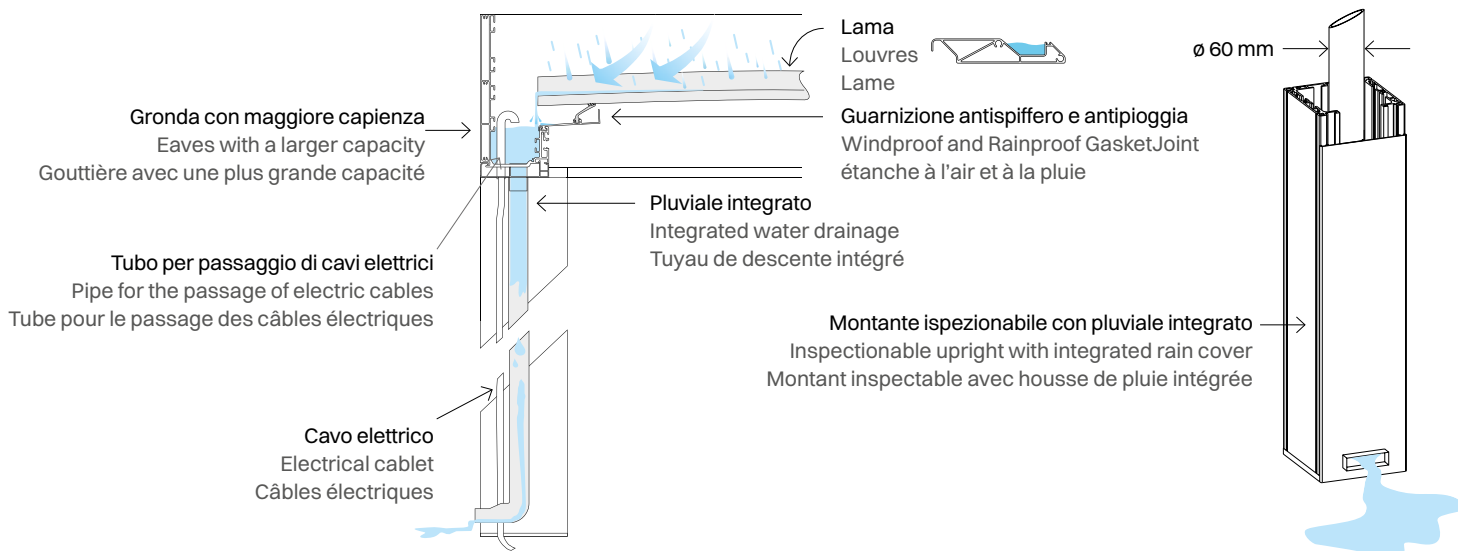

OPTIONALS / OPTIONS

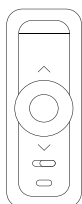

Radiocomando di serie
Remote controls series
Télécommandes série

Apri, chiudi e orienta le lame,
e gestisce l'illuminazione.

Opens, closes and directs the louvers,
and manages lighting.

Ouvre, ferme et oriente les volets,
et gère l'éclairage



Led



Faretti segnapasso

Step lights

Lampes Led Starlight



RGB



Faretti sul frangitratta

Intermediate-bar spotlights

Lampes Led sous barre intermédiaire



Bluetooth



USB



Wifi



Audio system



Scheda tecnica ALx - Smart - Blue

Sezione di profili **AL2** / profile section AL2 / Section des profiles AL2

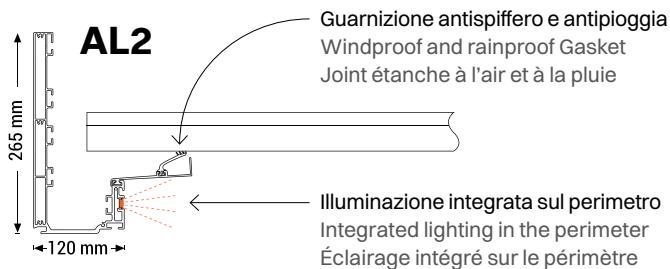

Trave perimetrale AL2 / perimetral beam AL2 / poutre périphérique AL2

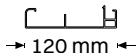

Profilo compensatore di finitura (Standard)
Finishing compensator profile (Standard)
Profil compensateur de finition (Standard)

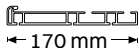

Profilo compensatore (Optional) per eventuali chiusure perimetrali
Compensator profile (Optional) for perimeter closure
Profil compensateur (Optional) pour les fermetures périmétriques éventuelles

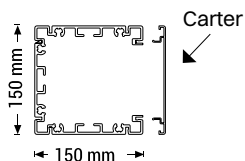

Montante ispezionabile / Inspectionable upright / Montant inspectable

Sezione di profili **AL4** / profile section AL4 / Section des profiles AL4

Dimensioni massime: cm 600 X 800, **senza montanti intermedi.**
Maximun size: cm 600 X 800, **without intermediate pillars.**
Taille maximum: cm 600 X 800, **sans poteau intermédiaires.**

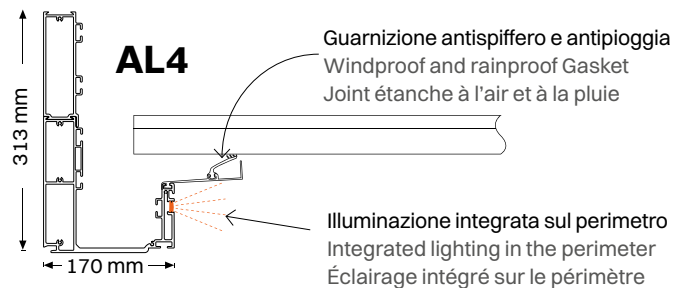

Trave perimetrale AL4 / perimetral beam AL4 / poutre périphérique AL4

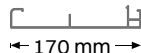

Profilo compensatore di finitura (Standard)
Finishing compensator profile (Standard)
Profil compensateur de finition (Standard)

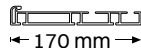

Profilo compensatore (Optional) per eventuali chiusure perimetrali
Compensator profile (Optional) for perimeter closure
Profil compensateur (Optional) pour les fermetures périmétriques éventuelles

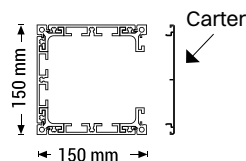

Montante ispezionabile / Inspectionable upright / Montant inspectable

Lame per struttura AL2 e AL4 / Louvres for structures AL2 and AL4 / Lame pour structures AL2 et AL4

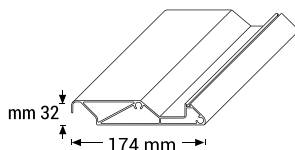

Lama orientabile
louvers tilting
lame réglable

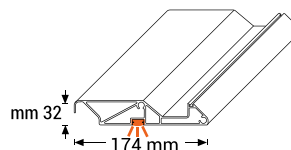

Lama orientabile con illuminazione integrata (applicabile solo sul modello ALX)
Louvers tilting with integrated lighting (applicable only on the ALX model)
Lame réglable avec éclairage intégrée (applicable uniquement sur le modèle ALX)

Caratteristiche tecniche Alx - Smart - Blue (con trave AL2)

Configurazione moduli singoli / Single structure configuration / Configuration à structure unique

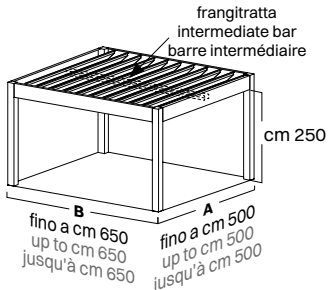

dimensione massima
maximum size
taille maximum

cm 500 x 650

Modulo singolo autoportante con 4 montanti / Single self-supporting module with 4 pillars / 4 piliers même pour la taille maximale

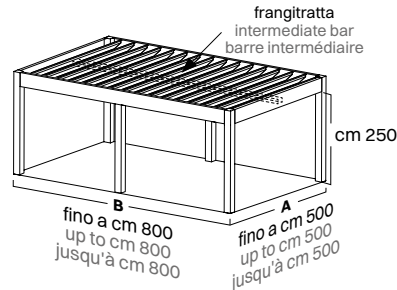

dimensione massima
maximum size
taille maximum

cm 500 x 800

Modulo singolo autoportante con 6 montanti / Single self-supporting module with 6 pillars / 6 piliers même pour la taille maximale

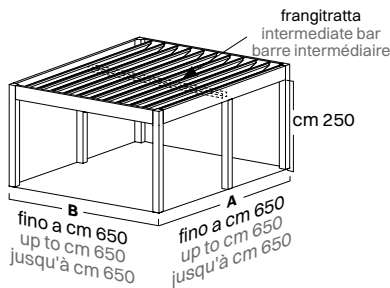

dimensione massima
maximum size
taille maximum

cm 650 x 650

Modulo singolo autoportante con 6 montanti / Single self-supporting module with 6 pillars / 6 piliers même pour la taille maximale

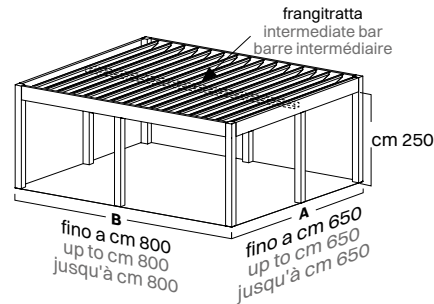

dimensione massima
maximum size
taille maximum

cm 650 x 800

Modulo singolo autoportante con 8 montanti / Single self-supporting module with 8 pillars / 8 piliers même pour la taille maximale

Configurazione strutture accoppiate / Coupled structure configuration / Configuration des structures couplées

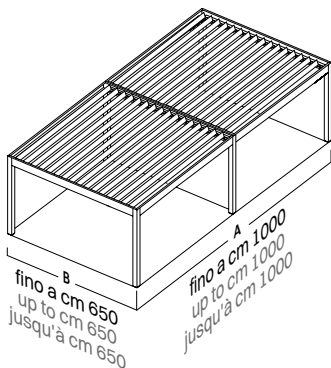

Moduli accoppiati sulla sporgenza / Coupled modules on the projection / module de couplage jusqu'à projection

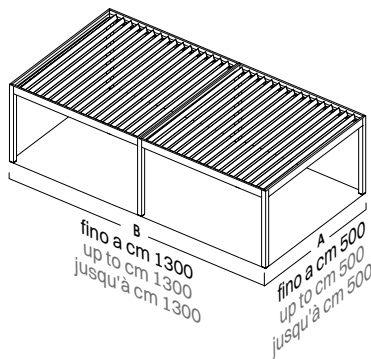

Moduli accoppiati sulla larghezza / Coupled modules on the width / module de couplage jusqu'à projection

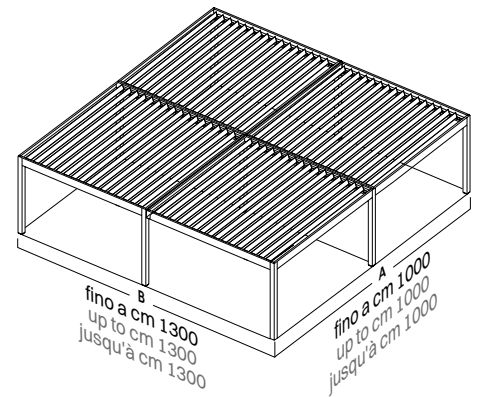

Moduli accoppiati sulla larghezza e sporgenza / Coupled modules on the width and projection / module de couplage jusqu'à projection et largeur









Scopri di più
sulle pergole bioclimatiche
QBox Shade

Prov. le Martano—Soletto Km. 1.500
73025 Martano (LE), Italy
(+39) 0836 57 14 16

•
www.sprech.com
info@sprech.com

